



# MEGH250SFQT



JOB NAME: \_\_\_\_\_  
 DATE: \_\_\_\_\_  
 TYPE: \_\_\_\_\_

## DESCRIPTION

Mega flood with heavy duty, die cast slipfitter for 2 3/8" O.D. tenon size. Slipfitter joint adjusts over 180° arc. Lamp supplied.

## SPECIFICATIONS

### Finish:

Chip and fade resistant polyester powder coating

### Housing:

One-piece die cast aluminum with die cast door frame held captive when opened

### Lens Gasket:

High temperature extruded silicone set in die cast retaining groove. Remains in place during relamping

### Lens:

Thermal, tempered shock resistant glass, 5/32" thick

### Reflector:

High quality anodized aluminum eliminates redirected energy to prolong lamp life. Contoured for maximum horizontal and vertical beam dispersion.

### UL Listing:

Suitable for wet locations. Suitable for mounting within 4' of the ground.

### Socket:

3 socket positions customize beam spread to the application (center position is standard). Porcelain socket pulse rated 4kv, 1500 watts and 600 volts, reinforced with cat's eyes for added durability. Silicone and fiberglass #14 gauge socket leads rated for 200° C. Plated screw shell designed to resist corrosion with spring loaded center contact

### EPA:

2.1

### Patents:

RAB sensor and fixture designs are protected under U.S. and International Intellectual Property laws.

### Quad Tap:

Fixture works with 120, 208, 240 and 277 Volts

### Color:

Bronze

### Weight:

32.68

## DIMENSIONS

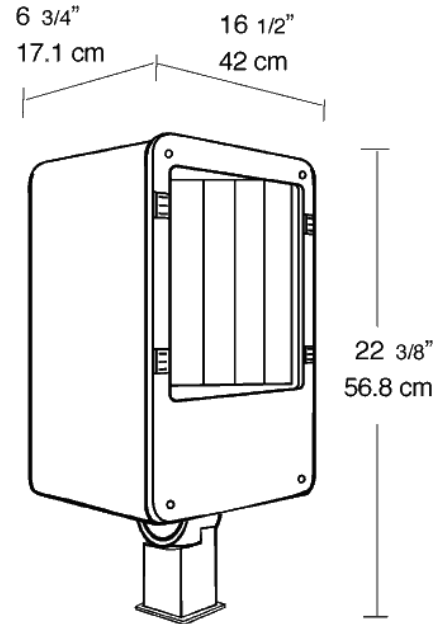

## ORDERING INFORMATION

Metal Halide Lamp supplied with fixture	Total Watts	Lamp Type	Lamp Base	Ballast	Starting Amps/ Operating Amps				Input Watts	LAMP ANSI	Initial Lumens	Lamp Hours
					120V	208V	240V	277V				
	250	ED28	Mogul	CWA-HPF QT	2.2/2.5	1.3/1.5	1.1/1.3	1.0/1.1	295	M58	21000	10000

**Factory Installed Options**  
 Add suffix to Catalog Number

Swivel Photocontrol wired for 120V (/PCS)  
 Single fusing for 120 and 277 volt. (/F)  
 Double fusing for 208 and 240 volt. (/FF)

Button Photocontrol wired for 480V (/PC4)  
 Button Photocontrol wired for 277V (/PC2)  
 Button Photocontrol wired for 120V (/PC)  
 480 volt ballast (substitute /480 for QT) (/480)

Note: Specifications may change without notice